

# **SILENT OIL FREE AIR COMPRESSOR**

## ***OPERATION MANUAL***



**ISO9001:2008**

Thank you for purchasing our **Silent Oil Free Air Compressor**, one of the best in the industry for low noise air compressors with clean air.

**This** product is manufactured to high quality standards and it is safe and fit for purpose at time of sale, but all tools can be dangerous if the correct precautions are not taken.



**Warning!**

When using compressors, basic safety precautions should be always followed to reduce the risk of fire, electric shock and personal injury.

Read all these instructions before attempting to operate this product.

Keep these instructions with the compressor.

Save these instructions for future reference.

**1.  Personal Safety**

***Symbols used on the air compressor.***



Read the operator instructions



Warning shock hazard



Warning high temperature parts



Warning the compressor is automatic  
and can start unexpectedly



Electrical shock



High voltage



No touching



B type instrument

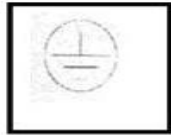

Ground protector



ON



OFF



### ***Read this manual***

In order to ensure working safety read this manual and thoroughly understand how to turn the compressor on and off and to control the airflow.

## **2. Operational Safety**

### ***Do not eat, drink or smoke in the work area.***

Do not eat, drink or smoke while using this machine or in the work area.

### ***Do not touch the compressor cylinder head.***

During operation the cooling fins of the cylinder head and the braided air pipe will become very hot. Even after using these will remain hot for some time.

Avoid coming into contact with these. Do not leave inflammable objects near the compressor.

### ***Do not let children or pets in the work area.***

Do not let children or pets come into contact with the compressor, high-pressure hose, air tools, main cable or work area.

***Do not use the product for excessive time periods.***

It will work better and safer at the rate for which it was intended. See *section 5 Maintenance, Care and repair*. Please note that these compressors are designed for dental apparatus, medical care, laboratory equipment, scientific research, industrial production and daily life.

***Do not abuse the hose/cable***

Never pull the compressor by the air hose or electrical cable.  
Keep hose/cable away from heat and sharp edges.  
Do not touch the metal plug pins when connecting or removing the electrical plug.

***Do not run the compressor in damp conditions.***

The compressor should never be used in an area where it could be exposed to water or excessively damp conditions.

***Do not make any alterations to the air tank***

The air tank is made to conform to the relevant European safety standards and under no circumstances should the air tank be altered by welding or any other means.

***Disconnect the compressor from power supply when maintaining.***

Before carrying out any maintenance on the compressor. Always switch off and unplug the compressor from the power supply. Ensure that all the compressed air has been released from the air tank.

***Maintenance of electrical components***

You must ensure that a suitably qualified person carries out repairs and maintenance of electrical components.

***Avoid unintentional starting of the compressor.***

When the machine is not in use please depress the pressure switch, to ensure that it doesn't start up unexpectedly.

***WARNING! Use recommended high-pressure hoses and couplings***

High-pressure hoses, fittings and couplings are important for the safety of the appliance. Use only hoses, fittings and couplings designed for usage with air compressors. If in doubt please consult the local dealer.

***Before disconnecting the air hose from the compressor***

For safety close the pressure switch and discharge residual pressure in the air hose before disconnecting.

***Guard against electric shock***

Use a RCD (residual current device) to provide protection against electrical shock.

***Before moving the compressor***

The compressor air tank must be discharged before the machine is transported.

***Keep work area clean***

Cluttered areas invite injuries.

### ***3. Setting up the Compressor***

**Important:**

Use the compressor only for the purpose for which it was designed. The compressor is designed for use under its air flow capacity; do not attempt to use it exceeding its own technical specifications. The manufacturer assumes no responsibility for any damages resulting from improper use for non-compliance with the instructions described in this manual.

The compressor is for use by competent persons only.

***Before Operation******Check package contents******Check for damage***

Before using this item check each part is undamaged. Check all pipes are firmly connected. Inspect the air tank to ensure that it has not been damaged.

***Save packaging***

Save major packaging for return of product in the event of service or repair.

***Electrical supply***

Before using the air compressor please check that you have a suitable electrical supply to support the requirements of the motor unit.

Please ensure your mains power supply corresponds to the power rating on the data label on the machine.

**Electrical Cables**

Ensure that all cables are damage free before connecting to the power supply.

**Using extension cables**

Use an extension cable, which is no more than 10metres long and has a conductor cross-section of at least 1.5mm<sup>2</sup> i.e. a heavy-duty cable. Using an excessively long or thin-wired extension cable will cause severe damage to the motor. Always fully unwind extension cables. If using extension cables outdoors always use a cable which is marked for outdoor use.

**Always maintain a clear area around the compressor**

It is very important that the compressor is well positioned to ensure there is an adequate airflow around the machine. The compressor should be well situated to ensure it has 50cm space free of obstacle around its air tank and motor.

**Ensure that the compressor draws clean air**

For the correct function and longevity of your air compressor it is important that the air which is drawn into the compressor is clean. The compressor should not be used in an area where the air is contaminated with dust.

**Place the compressor on flat ground**

Ensure that the compressor is placed on ground, which is flat and does not have an incline greater than 15°. If the compressor is placed at an angle greater than 15° in any direction, damage to the motor will result.

**Do not operate the compressor without the air filter installed.**

Operating the compressor without the air filter will cause severe damage to the motor.

**Cleaning**

Clean the items with a soft brush or a wiper moistened with a suitable biodegradable solvent. Do not use inflammable liquids like petrol or alcohol, they are a fire risk and will damage the finish and plastic parts. Ensure that the cooling fins on the motor are kept clean. Fins which are heavy with dust, have poor cooling properties and the motor will be overheated and damage will occur.

**Faults**

Have the air compressor repaired by a competent person.

Use only genuine replacement parts, which are available from the authorized dealer or distributor.

Do not use modified or non-genuine parts.

**Maintain air compressor with care**

Keep the air compressor clean for better and safer performance.

Follow instructions for changing accessories.

Inspect the air compressor and extension cables/hoses occasionally. Have them repaired by a qualified person or authorized service body.

**Check for damaged parts.**

Do not use the air compressor with damaged parts, before further use the air compressor must be carefully checked by a qualified person to determine that it will be operated properly. Check the breakage of parts, mountings and other conditions that may affect its operation. An authorized service centre should properly repair a damaged part, unless indicated otherwise in the instruction manual.

**4. Brief introduction**

Our silent air compressor features compact structure, stable performance, large flow rate, easy operation and maintenance. Particularly the machine can not contain any oil fume. Because the air for dental apparatus must not contain any oil, this machine can be used as an independent air supply machine for dental therapeutic apparatus. It also can be used in other areas such as medical care, laboratory equipment, scientific research, industrial production and daily life where clean air is demanded.

The structure of our silent oil free air compressor is shown in attached file Fig.1. All units in the machine sit on a cylindrical pressure vessel called air tank. Motor is the main part of the air compressor. A motor drives directly the eccentric wheel-connecting bar system making the piston move reciprocally. The piston is made from high temperature-resistant and abrasion-resistant non-metal material and is able to work without lubrication for a long time. Compressed air discharge enters in the air tank; a pressure gauge displays the pressure in the tank. When the pressure inside rises to 8 bar, power is automatically cut off by a pressure switch, the compressor is shut off. When the pressure inside decreases to 5 bar, power is turned on by the pressure switch and the compressor starts again and the pressure in the tank gradually rises again. This happens repeatedly. In addition, check

valve, drain valve, safety valve and solenoid valve are installed on the air tank.

## **5. Transportation and storage**

The machine should be transported and stored in following condition:

Ambient temperature:-40°C~55°C

Relative humidity:≤95%

Atmosphere pressure: 500Hpa-1060Hpa

## **6. Installation, test and operation**

### (1) Installation

- a. The machine should be operated in the room with temperature of 5-40°C and relative humidity not greater than 80%. Surrounding area of the machine should be clean, dry, free of corrosive gas, well ventilated and indirect sunlight.

**★ Note: Special power line for the machine is recommended with short circuit protection and reliable grounding device.**

- b. After unpacking check the machine for any missing parts and damages, check accessories and spare parts and technical documents supplied together with the machine according to the packing list.
- c. Take off the air inlet nut, install the air intaker and keep the pipe facing down.
- d. Connect air supply pipe with the quick coupling
- e. Check if drain valve is off and pressure switch is at the position of "off"(switch off position) Electrical connection: check if power supply is normal. Insert the plug of the machine into power supply socket. Installation of the machine is completed.

### (2).Test run of the machine

- a. Close drain valve and air outlet ball valve. Turn the operation handle of pressure switch to "ON" the machine will start immediately. The reading of pressure gauge will slowly rise with increasing pressure inside the air tank. When the reading of pressure gauge reaches 8 bar, pressure switch activates, the power supply is cut off, machine stops running. At the same time the solenoid valve activates to release high pressure in the cylinder of motor so that the machine can be started again.
- b. During the period when the machine stops running observe if the reading of pressure gauge is decreasing. If there is no leakage of air in the machine, open air outlet valve to begin supply of compressed air. When the pressure in the air tank decreases to 5



bar, pressure switch resets and power supply resumes, the machine starts running again. The pressure in air tank increases again. If the machine can automatically stop and start, the machine works normally.

- c. Turn the operation handle for pressure switch to “off” position (switch off position), then pull out the plug of the machine. Test run is completed.

(3). Operation

- a. To operate DA series oil free air compressor correctly and safely, read carefully this operation instruction.
- b. Insert the plug of the machine in power socket of single-phase 10A/16A/20A .Open air outlet valve, turn the operation handle of pressure switch to “ON” position, the machine will run in a normal condition.

**Note:** Suitable type of air compressor should be selected basing on air consumption.

## **7. Maintenance**

(1). Draining of air tank

The frequency for draining is depended on environment condition and operation time, but usually once every 2-3 days. The way to drain off the condensated water is as follows:

Put the drain pipe which connects with the drain valve quick coupling in a container, with compressed air in the air tank slowly turns counterclockwise the knob on the drain valve to drain off the water in the air tank until all accumulated water comes out from the pipe. After that turn tightly clockwise the knob to ensure no leakage.

(2). Change of air filter core

An air filter is installed on air inlet of the motor to prevent the dust in the air from entering the air compressor and reduce noise. After being used for a period of time the filter core in the air filter will get clogged. In a result sucking capacity of the air compressor will be reduced, therefore the filter core must be replaced regularly. The way of replace is as follows: open the lid on the air filter, take out the old filter core, put in a new one, and then close the lid.

(3) Adjustment of pressure switch

Pressure switch is used for controlling the stop and start of the air compressor to ensure correct pressure of compressed air in the air tank. If the pressure of compressed air in the air tank is found not to be in the range set by the manufacturer (range: the pressure at which the air compressor will stop running is 8 bar +/-0.2 bar; the pressure

at which the air compressor will restart running is 5 bar +/-0.2 bar) the pressure switch must be adjusted again to set correct range. The way to adjust is as follows. Open the casing for the pressure switch; adjust the setting screw for maximum pressure (turning clockwise makes activation pressure higher, so the pressure at which the air compressor stops running will be higher) and the setting screw for pressure difference (turning clockwise makes larger pressure difference, that is, the difference between the pressure at which the air compressor starts and stops will be larger) respectively. Careful adjustment will make the activation pressures the same as the range set by the manufacturer.

## 8. Quality Inspection List

Reason Problem	Pressure low	Pressure high	High noise level	The motor overheated	The motor can't restart	Air leak
Pressure switch broken	✓	✓				
Starting capacitor broken					✓	
Safety valve broken.	✓	✓				✓
The drain valve is leaking	✓					✓
Air outlet valve broken	✓	✓				✓
Piston ring broken	✓		✓			
Overload protector cut off.(push the button for re-start)					✓	
The holder of aluminium alloy cracked			✓			
Solenoid valve broken	✓				✓	
Check valve broken			✓		✓	
Voltage less than 200V				✓	✓	
Outside temperature is too low					✓	
The air intaker is blocked	✓					

The air intaker is loose			√			
Screw loose			√			
The compressor isn't on flat ground			√			
The air inlet and outlet valve is damaged	√		√			
The surrounding area of the machine isn't well ventilated				√		

### 9. Split-up drawing of motor and maintenance

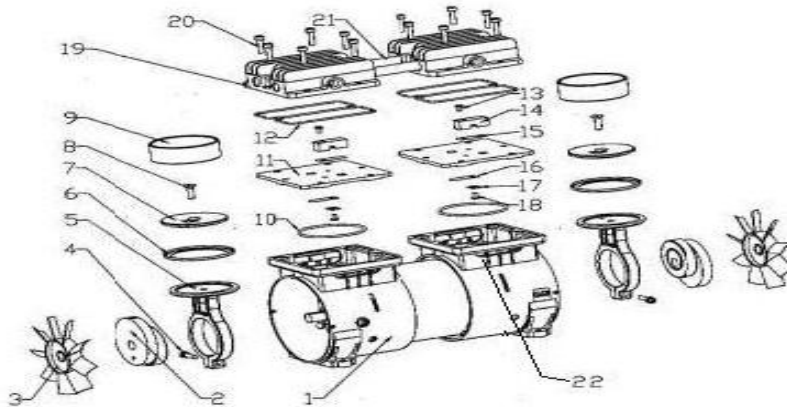

1 Cast Alu shell units	9 Cylinder Jacket	17 Valve gasket
2 Eccentric wheel units	10 Gasket of cylinder jacket	18 Screw of valve
3 Fan	11 Plate valve	19 Cylinder head
4 Screw of connecting rod	12 Gasket of cylinder Head	20 Screw of cylinder head
5 Connecting rod	13 Screw of plate valve	21 Connecting pipe
6 Piston ring	14 Fix plate	22 Holder of aluminium alloy
7 Plate	15 Air outlet valve	
8 Screw of plate	16 Air inlet valve	

## ***Maintenance procedures:***

1. Make note and stick label for the direction of air inlet and outlet in order to rebuild in the cylinder head.
2. Takeoff the screw of the cylinder head and *cylinder head*.
3. Takeoff the gasket of cylinder jacket from cylinder head.
4. Takeoff the cylinder plate valve.
5. Takeoff the cylinder jacket, plate, piston ring.
6. Check the quality of gasket of cylinder head, piston ring, cylinder jacket, gasket of cylinder jacket, air outlet valve and air inlet valve, and find out the broken parts.
7. Clear the scrap on the plate with the water-solubility impregnant.
8. Put the piston ring in the connecting rod, and then cover the plate.
9. Refix the piston ring, glue the screw of the plate and turn tightly.
10. Cover piston ring with cylinder jacket carefully, you need incline the cylinder jacket to avoid damaging the piston ring.
11. Put the air inlet and outlet valve, and fix plate in the original place.
12. Glue the screw of valve and turn tightly.
13. Install the gasket of cylinder jacket to the bottom of the plate valve and place the plate valve on the cylinder jacket. Make sure the cylinder jacket is correctly equipped in the gasket of cylinder jacket.
14. Check the air direction of inlet and outlet is correct.
15. Put the gasket of cylinder head on the flute of cylinder head.
16. Cover the plate with cylinder head, and keep the correct direction of air inlet and outlet again.
17. Tie up the screw of cylinder head.

## ***10. Packing list***

1. Air compressor, 1pc;
2. Brochure, 1pc
3. Air intaker, 1pc